

## AE-DS45B & AE-DS52B Countertop Reversible Sheeters

American Eagle: Value, Quality, and Reliability



**Perfectly stretched and sheeted products every time!**

- Croissants
- Pastry Puffs
- Danish rolls
- Cookie dough
- Pizza dough
- Pie crusts

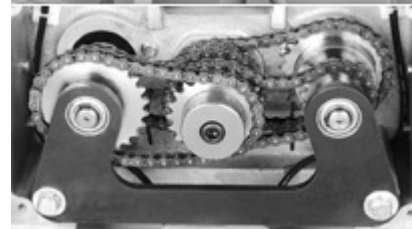

Permanently lubricated, heavy-duty alloy steel gears for years of worry-free use

**Let us help with your baking operation's efficiency!**

- Saves time and labor, no extensive training required
- Make wrinkle-free sheets of product ready for cutting or topping
- Allows you to focus on important things like your recipe & sales
- Produce a wide variety of products with adjustable thickness
- Unbeatable value pricing. Contact an AE representative today!

**Standard Features**

- Handle adjusts thickness for a variety of needs. Convenient reverse/forward switch
- Durable, heat treated alloy steel belt and chain drive
- Convenient fold-up design suitable for countertops
- Powerful motor with totally enclosed, permanently lubricated bearings
- Heavy-duty safety guard encloses moving rollers
- Conforms to the highest food sanitation standards. NSF No. 8, ETL, CE, CSA Approval
- Frame and housing construction from quality polished aluminum alloy and stainless steel
- Sanitary, heavy-duty PVC fiber conveyer belt with precise, tear-free rollers.

**Standard Warranty**

- 1 year parts and ninety days labor
- Must register with American Eagle

**Specifications Summary (See reverse for details)**

Model	Motor	Voltage	Roller Size Diameter x L	Overall Dimensions W x L x H	Maximum Dough Batch	Adjustable Thickness	Working Surface W x L	Ship Weight (Lbs)
AE-DS45B	½ H.P.	220V/60Hz/1Ph	3.5" x 17.7"	32" x 70" x 24"	11 Pounds	0.0"-1.18"	16.9" x 66.9"	305 (258 net)
AE-DS52B	½ H.P.	220V/60Hz/1Ph	3.5" x 20.5"	35" x 82" x 24"	11 Pounds	0.0"-1.57"	19.7" x 78.7"	321 (271 net)

Contact an American Eagle representative today to find the right sized sheeter for your bakery's volume!

# AE-DS45B & AE-DS52B Countertop Dough Sheeters

## Specifications

*Due to continuous product improvement, specifications may change without notice*

<p><b>Motor:</b> ½ HP &amp; 4 Amps. Motor overload protection w/ reset button. Totally enclosed to prevent oil leaks or food contamination.</p> <p><b>Transmission:</b> Easy-to-maintain gear belt and chain system. Transmission is completely enclosed and permanently lubricated for years worry-free operation.</p> <p><b>Electrical:</b> 220V /60 Hz /1Ph 6 foot long cord with three wire ending. Installation must be made by qualified electrician in accordance with all applicable laws &amp; codes.</p> <p><b>On/Off Switch:</b> Easy to find red and green buttons located on front of machine. Switch controls forward and reverse direction.</p> <p><b>Construction:</b> Heavy-duty polished aluminum alloy housing. Stainless steel and PVC fiber conveyer belt meets industry sanitation demands.</p> <p><b>Enamel Finish:</b> Powder white paint. Heat treated to resist rust, scratches, and dents.</p>	<p><b>Safety Guard</b>          Prevents operator contact with moving rollers. Machine will automatically shuts off if safety cover is removed.</p> <p><b>Capacity:</b> 11 (5 Kg) of dough per batch can be rolled onto the conveyer belt. Max sheet width determined by roller length. Max sheet length determined by belt surface.</p> <table border="1"> <thead> <tr> <th></th> <th>Width</th> <th>Length</th> </tr> </thead> <tbody> <tr> <td>AE-DS45B</td> <td>43 cm 16.93 in</td> <td>170 cm 66.93 in</td> </tr> <tr> <td>AE-DS52B</td> <td>50 cm 19.69 in</td> <td>200 cm 78.74 in</td> </tr> </tbody> </table> <p>Belt moves approximately 3 cm/sec.</p> <p><b>Adjustable Thickness</b>          Side handle quickly adjusts to the precise thickness you require. Handle operates between 0in (1 mm) and 1.18" (30 mm-DS45B) or 1.57" (40mm-DS52B)</p> <p><b>Stored Dimensions</b>          AE-DS45B Stored Position:          25.88"W x 27.5"H (66cm x 70cm)          AE-DS52B Stored Position:          28.43"W x 33.33"H (72.5cm x 85cm)</p>		Width	Length	AE-DS45B	43 cm 16.93 in	170 cm 66.93 in	AE-DS52B	50 cm 19.69 in	200 cm 78.74 in	<p><b>Shipping Information</b>          Freight Class: 85          Crates are affixed to a skid (pallet). The weight and dimensions of this skid are included below and may vary from shipment to shipment.</p> <p><b>AE-DS45B Dimensions</b>          Net Weight: 258 lbs (117 kgs.)          Ship Weight: 305.8 lbs (139 kgs.)          Packing Crate: 32.2" x 29.2" x 35.7"          (82 cm x 74.5 cm x 91.0 cm)</p> <p>Machine:          Overall Width = 32.28" (82 cm)          Overall Length= 69.69" (177 cm)          Overall Height= 24.41" (62 cm)</p> <p><b>AE-DS52B Dimensions</b>          Net Weight: 271 lbs. (123 kgs.)          Ship Weight: 321.2 lbs (146 kgs.)          Packing Crate: 36.5" x 29.8" x 38"          (93 cm x 76 cm x 97 cm)</p> <p>Machine :          Overall Width = 35.29" (90 cm)          Overall Length = 81.89" (208 cm)          Overall Height = 24.41" (62 cm)</p>
	Width	Length									
AE-DS45B	43 cm 16.93 in	170 cm 66.93 in									
AE-DS52B	50 cm 19.69 in	200 cm 78.74 in									

### Dimensions

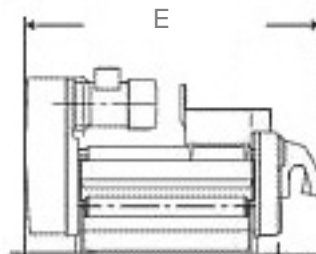
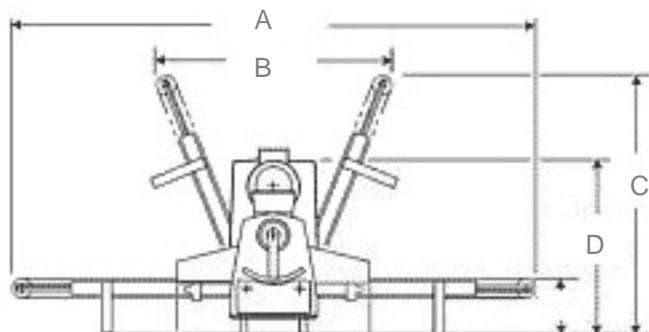

AE-DS45B		
	in	cm
A	69.69	177
B	25.88	66
C	27.45	70
D	24.41	62
E	32.28	82

AE-DS52B		
	in	cm
A	81.89	208
B	28.43	72.5
C	33.33	85
D	24.41	62
E	35.29	90