

AE-1220 Spiral Mixer

40 Qt Bowl, 44 Lbs of Dough

American Eagle spiral mixers meet every baker's challenge: high-capacity, high-efficiency machines at an affordable price. Their exceptional reliability make it ideal for busy cooks by decreasing mixing times and maintenance. This versatile mixer makes a variety of dough from bagels to pizza.

The machine of choice for busy chefs

- Shorter mixing times
- Higher output
- Consistent results

Spiral Mixing Technology: The Secret to Better dough

Why do European artisan breads taste better? The most important thing besides your recipe is the way dough is handled. Used for decades in European-style bakeries, spiral mixers can imitate hand-kneading and rolling motions. The gentle coordinated movement of bowl and agitator controls blending while preventing overdeveloped dough. The dough stays cooler, mixes in less time, and has better consistency.

Features

- Heavy-duty agitator is 25% thicker than industry leader
- Handles heavier pizza & bagel dough with ease
- Reversible mixing action makes better dough, and in less time
- Heavy-duty construction and powerful two-motor system
- Easy maintenance and time-saving versatility
- Heat treated enamel coating resists scratches, rust, and dents
- Mounted on castors for extra mobility and easy maintenance
- Overload relay protects motor and transmission
- Approvals: NSF No. 8, ETL, CE, CSA

Standard Accessories

- Stainless steel extra durable spiral agitator
- Stainless steel stationary bowl w/ 40Qt Bowl
- Stainless steel safety guard
 - Locking mechanism prevents operation when lifted
 - See through to bowl guard
- Two 60 min timers automatically shift between high and low speed

Standard Warranty

- 1 year parts and ninety days labor
- Bagel and pizza dough rated at low speeds only
Use in high speed voids warranty
- Must register with American Eagle

Other Available Sizes:

- AE-3050 80 Qt Spiral Mixer
- AE-4060 100 Qt Spiral Mixer
- AE-5080 120 Qt Spiral Mixer
- Special Order: AE-75K & AE-100K Spiral Mixers



American Eagle: Value, Quality, and Reliability



Contact an American Eagle representative today to find the right sized mixer for your operation!

AE-1220 Spiral Mixer

40 Qt Bowl, 44 Lbs of Dough

Specifications

Due to continuous product improvement, specifications may change without notice

<p><u>Agitator (Arm) Specifications</u> Spiral Arm Motor: 1.5 HP (4 Amps) Overload protection w/ reset button.</p> <p>Arm Agitator Speeds: Low-148 rpm, High-284 rpm Manual (continuous) mixing</p> <p>Transmission: Belt-drive transmission made from specially patented, resilient fibers.</p> <p><u>Bowl Specifications</u> Capacity: 42 Quarts (40 Liters) 100% high polish stainless steel stationary bowl.</p> <p>Motor: 1/3 HP (7 Amps). Moves the bowl in coordinated fashion to arm.</p> <p>Bowl Guard See-through stainless steel guard stands up to the toughest challenges. Interlocking mechanism prevents mixing until guard is fully closed</p>	<p><u>Other Specifications</u> Quality Materials: High polish stainless steel meets food industry sanitation needs. Sturdy cast iron-frame. Non-porous food surfaces easily wipe off after use.</p> <p>Voltages: 220V /60 Hz / 3Ph Permissible voltage range: 198 Volts to 242 Volts (+/- 10%)</p> <p>Cord: 6 ft. flexible four wire cord. Electrical connections must be made by qualified personnel in accordance with applicable codes and regulations.</p> <p>Speed Mode: The machine must be turned off before shifting speed mode. Push red stop button, select High or Low Speed to turn on again.</p> <p>Timer: Each speed is automatically controlled by an accurate sixty minute digital timer, ensuring consistency. Machine can also operate with timer disabled.</p>	<p><u>Shipping Information:</u> Shipping Weight: Freight Class: 85 Net Weight: 330 lbs. (150 kgs.) Shipping Weight: 390 lbs.(177 kgs.)</p> <p>Crates are affixed to a skid (pallet). The weight of this skid is included above and may vary from shipment to shipment.</p> <p>Shipping Dimensions: 23"W x 35"D x 50"H (58cm x 89cm x 127cm)</p> <p>Dimensions: Foot Print = 26.4" x 13.4" (41.7cm x 38.0 cm) Overall Width = 18.9" (48 cm) Overall Depth = 29.1" (74 cm) Overall Height = 45.3" (115 cm)</p>
---	---	---

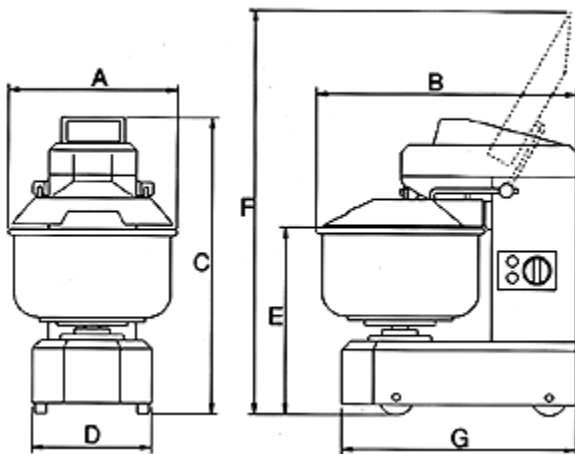

Dimensions		
A	18.9 in	48 cm
B	29.1	74
C	33.5	85
D	13.4	34
E	20.9	53
F	45.3	115
G	26.4	67

Specifications Summary

Bread Dough Capacity (Lbs)
 Flour Dough
 26 Lbs 44 Lbs

Bagel Dough Capacity
 Flour Dough
 20 Lbs 32 Lbs